

640, Curé-Bovin
Bolsbriand (Québec)
Canada, J7G 2A7

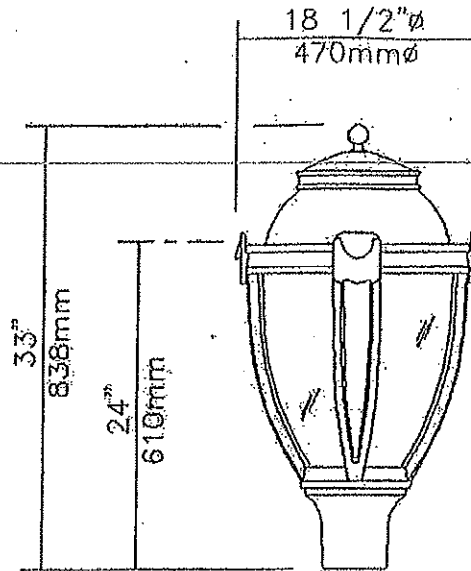

LIFE Science
NWU - 8/2/03

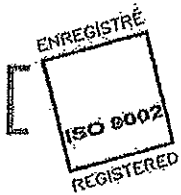

Qty 25 Luminaire 150MH-L80-PC-CS-SE3-QTA/277-SF80-BKTX

Description of Components:

Finial: Decorative cast 356 aluminum, mechanically assembled.

Hood: Cast 356 aluminum dome, mechanically assembled on the luminaire.

Guard: In a round shape with 4 arms, this guard is a one-piece cast 356 aluminum mechanically assembled to the filter.

Globe: Made of one-piece seamless injected-molded satin clear polycarbonate. The globe is assembled on the access-mechanism.

Lamp: 150 watts metal halide Pulse Start Type (not included) , ED 17 bulb, medium base.

Optical System: (SE3), I.E.S. type III (asymmetrical). Cutoff optical system. Multi-faceted hydroformed aluminum reflector brightened and anodized, mechanically assembled on the luminaire.

Ballast: High power factor of 90%. Primary voltage 120/208/240/277 volts, connected to 277 volts. Lamp starting capacity - 20F(-30C) degrees. Assembled on a unlized removable tray with quick disconnect plug.

Access-Mechanism: A cast 356 aluminum frame with latch and hinge. The mechanism shall offer toolfree access to the inside of the luminaire. An embedded memory-retentive gasket shall ensure weatherproofing.

Fitter: Cast 356 aluminum c/w 4 set screws 3/8-16 UNC. Slip-fits on a 4"(102mm) outside diameter x 4" (102mm) long tenon.

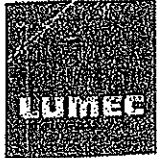

640, Curé-Boivin
Boisbriand (Québec)
Canada, J7G 2A7

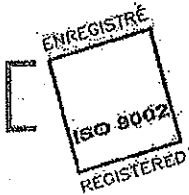
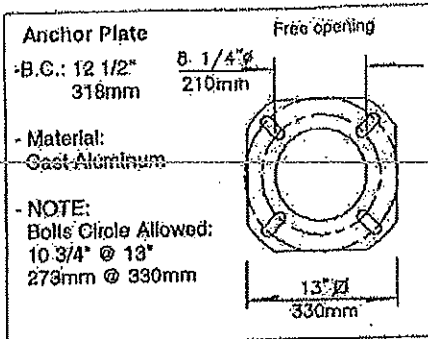
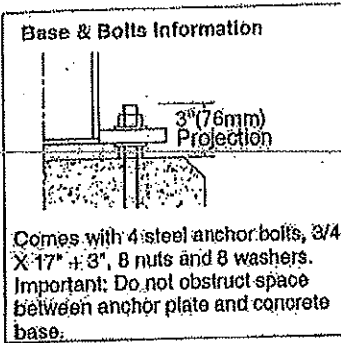

Qty	25	Pole	RA61U-12-FS1-BKTX
-----	----	------	-------------------

Description of Components:

Pole Shaft: Shall be made from a 4" (102mm) round extruded 6061-T6 aluminum tubing, having a 0.266" (6.8mm) wall thickness, welded to the pole base.

Joint Cover: Two-piece round joint cover made from cast 356 aluminum, mechanically fastened with stainless steel screws.

Pole Base: Shall be made from a 8 5/8" (218mm) round extruded 6061-T6 aluminum tubing base having a 0.148" (3.8mm) wall thickness, welded to both the bottom and top of the anchor plate.

Maintenance Opening: The pole shall have a 4" x 10" (102mm x 254mm) maintenance opening centered 25 1/4" (641mm) from the bottom of the anchor plate, complete with a weatherproof cast 356 aluminum cover and a factory assembled copper ground lug.

Base Cover: Two piece round base cover made from cast 356 aluminum, mechanically fastened with stainless steel screws.

Pole Options: (FS1), Single fuse and fuse-holder. Single fuse and fuse-holder.

Miscellaneous

Description of Components:

Wiring: Gauge (#14) TEW wires, 6" (152mm) minimum exceeding from luminaire.

Hardware: All exposed screws will be in stainless steel. All seals and sealing devices are made and/or lined with EPDM and/or silicone.

Finish: Color to be black textured (BKTX). Application of a polyester powder coat paint. (4 mils/100 microns). The chemical composition provide a highly durable UV and salt spray resistant finish in accordance to the ASTM-B117-73 standard and humidity proof in accordance to the ASTM-D2247-68 standard.

