

NOTES:

1. THE BOLLARD SHALL BE 316 STAINLESS STEEL WITH HIGHER IMPACT LOADING.
2. NU STANDARD BOLLARD PADLOCK TO BE PROVIDED BY OWNER.
3. CONCRETE PAD TO BE DESIGNED BY ENGINEER. (INCLUDING REINFORCEMENT, MIN #4 REBAR W/STIRRUPS)
4. THE SPACING OF THE BOLLARDS WILL BE APPROVED BY OWNER.
5. BOLLARD BY CALPIPE SSP04080.

**INTERNAL LOCKING REMOVABLE BOLLARD**  
NO SCALE

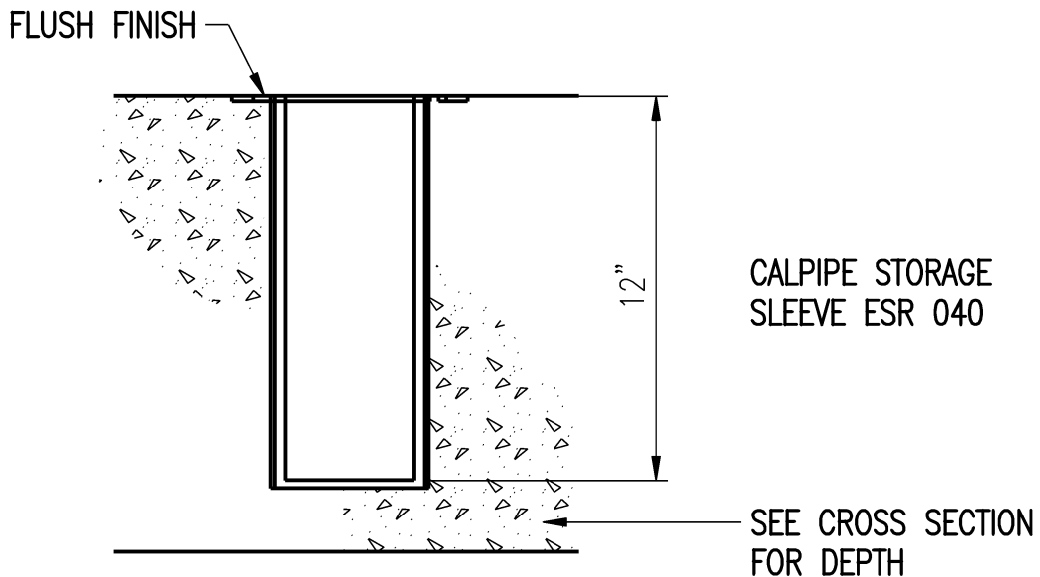
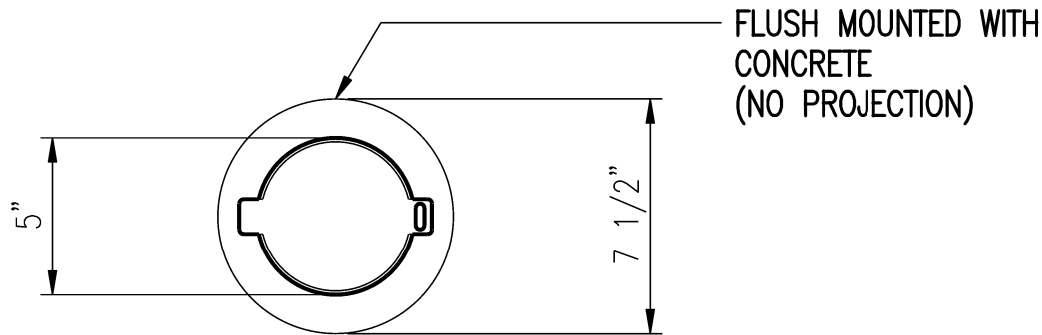

**BOLLARD SEAT**

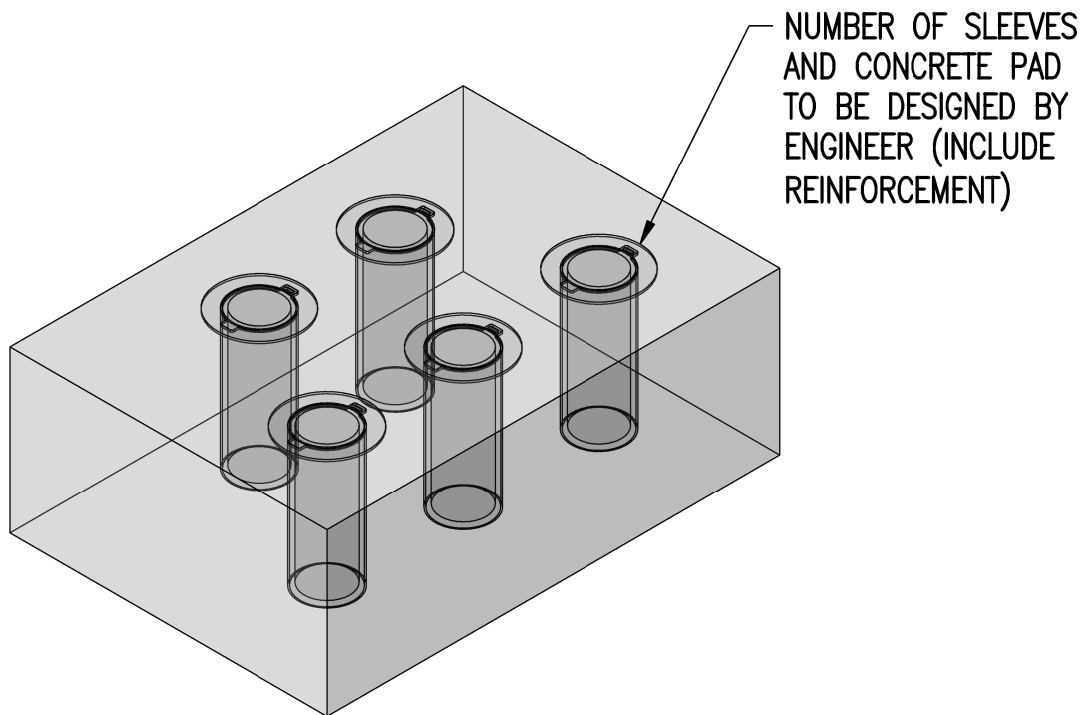

**BOLLARD STORAGE SLEEVE AND CONCRETE PAD**  
NO SCALE